

Fin Spider Micro 1 Arm

NFK's Micro Fin Spider is designed for balustrade applications, small feature panels or other lightweight applications.

Cast 304 stainless steel, suitable for internal applications. 316 s/s models is available on request.

Various point fixing options are available for this spider.

Available in satin or polished finish.

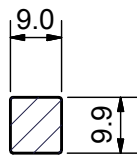
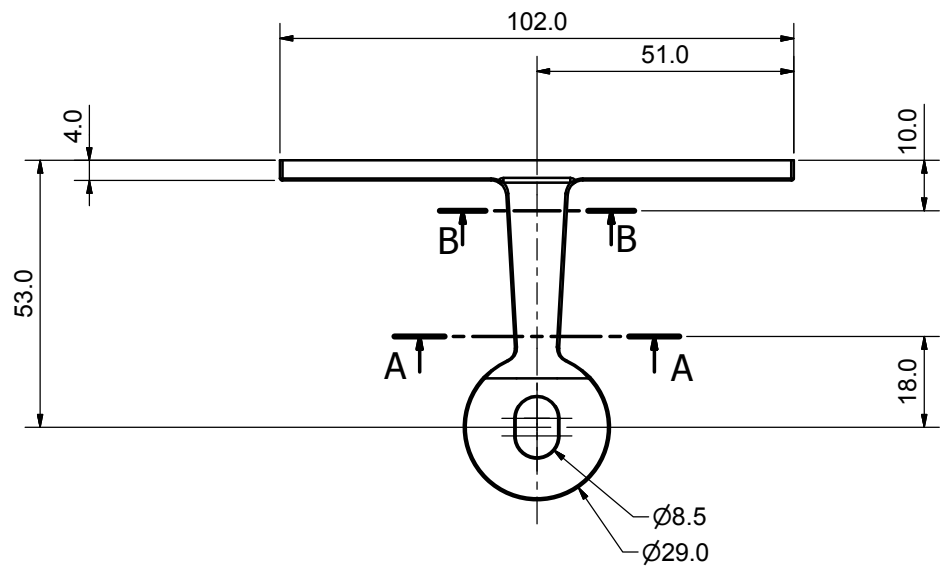

SECTION-A-A

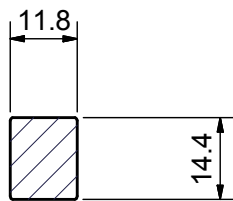

SECTION-B-B

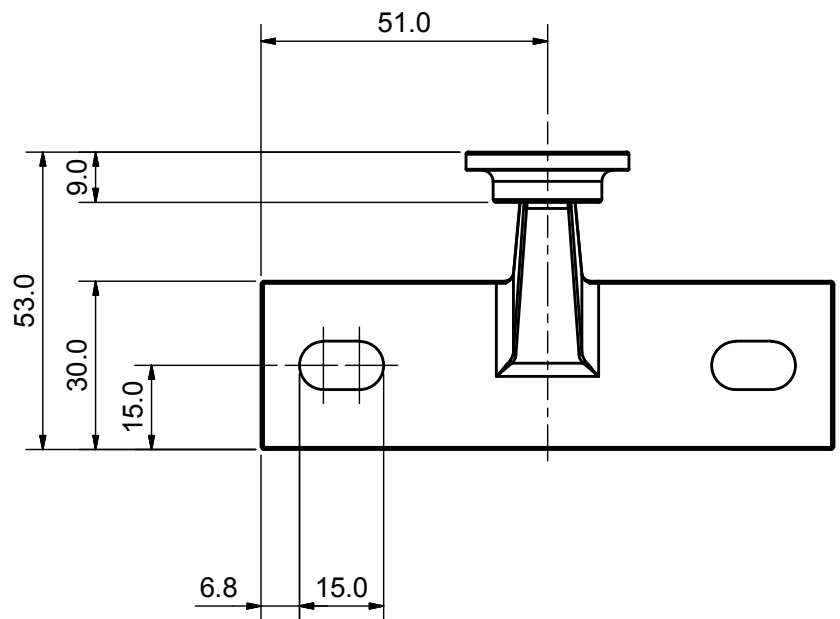

Description	Code
Fin Spider, Light Duty Single Arm 90°, Satin Finish	41-1003.01.77
Fin Spider, Light Duty Single Arm 90°, Polished Finish	41-1003.01.99